



Differential Pressure Switch QBM81-...

for air and nonaggressive gases

- For ventilation and air conditioning plants
- To monitor air filters, air flow, fan belts
- To monitor pressure in clean rooms, kitchens etc.
- Easy to mount
- >1 mio switching cycles
- Highly precise setting
- Long-term stability

Use

In ventilation and air conditioning plants to:

- Monitor differential pressure, underpressure and overpressure
- Monitor air filters and air flows
- Recognize torn fan belts

Differential pressure switches can be used in clean rooms, kitchens, etc.

Type summary

Type	Pressure range		
QBM81-3	0,2...3 mbar	20...300 Pa	0.08...1.2 inH ₂ O
QBM81-5	0,5...5 mbar	50...500 Pa	0.2...2 inH ₂ O
QBM81-10	1...10 mbar	100...1000 Pa	0.4...4 inH ₂ O
QBM81-20	5...20 mbar	500...2000 Pa	2...8 inH ₂ O
QBM81-50	10...50 mbar	1000...5000 Pa	4...20 inH ₂ O

Ordering

When ordering, please indicate quantity, name and product number. *Example:*

1 differential pressure switch QBM81-5

The accessory duct probe FK-PZ3 are included in the delivery.

Additional accessories must be ordered separately.

Mechanical design

The differential pressure switch QBM81-... consists of:

- Housing and cover
- Diaphragm
- 1 sheet-steel mounting bracket

Accessory duct probe connection kit (FK-PZ3):

- 2 duct adaptors
- 4 fixing screws
- 2 m tubing, 5/8 mm dia.

Accessories

For precise measurements, two additional duct probe sets must be delivered; see also data sheet CA1N1589E:

FK-PZ1 Set containing two stainless steel duct adaptors with rubber grommet

FK-PZ2 Set containing two duct adaptors with aluminum fixing rosettes, 4 screws

Technical design

The differential pressure between the two pressure connections deflects a spring-loaded diaphragm. This special diaphragm ensures the long-term stability of switching points.

Each type is engraved with individual scales for very precise adjustment. The adjustment options are illustrated in the 5 diagrams in Section "Functions" below.

Functions

Function diagram

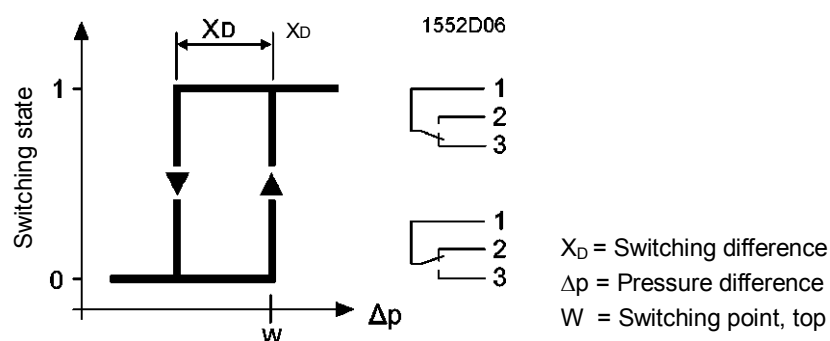

Switching points

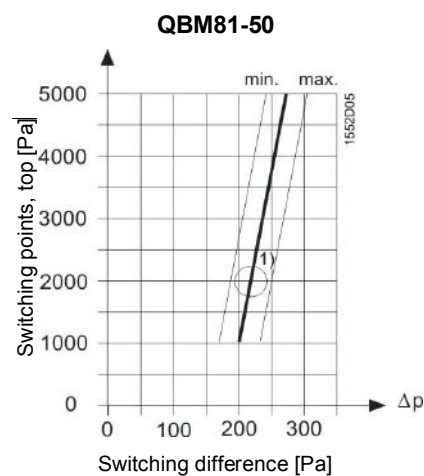
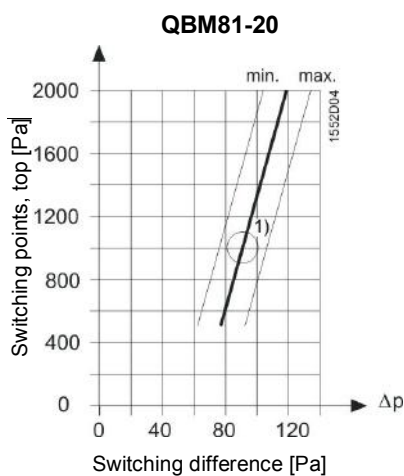
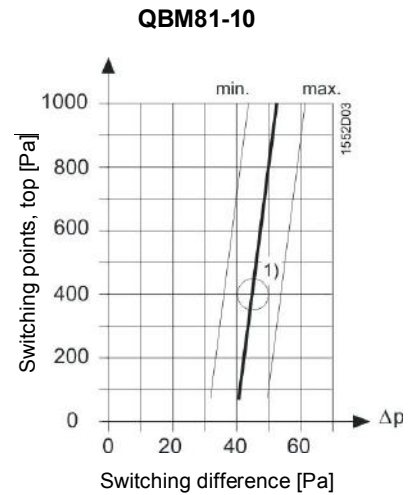
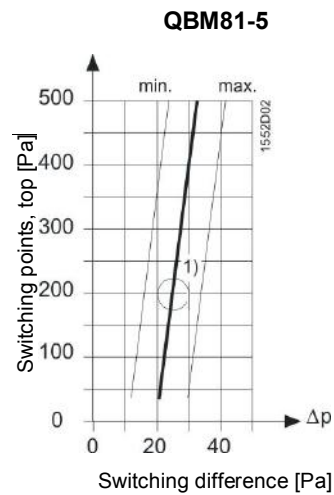
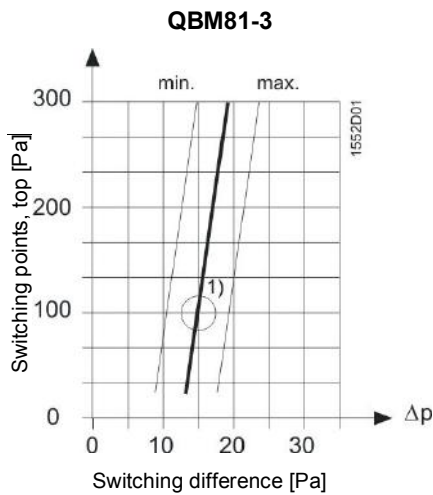

1) Factory setting

Application examples

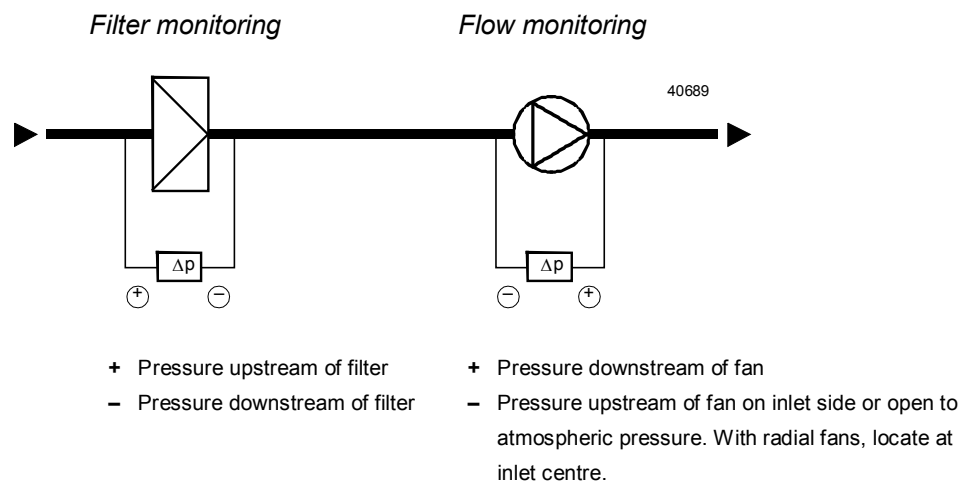

Mounting notes

Mounting instructions are enclosed with the differential pressure switch. The pressure switch is suitable for mounting on air ducts or walls. Vertical orientation is recommended, but any orientation is acceptable in principle. Mounting positions other than vertical affects the switching point of the differential pressure switch; see "Commissioning notes" below.

The pressure connection tubes can be any length, but the response time increases if longer than 2 meters.

Mount the pressure switch above the pressure connection points. To prevent accumulation of condensation, route the tubing to ensure gradual incline from the pressure connection points to the differential pressure switch (no looping).

Commissioning notes

Select the required setpoint using the setpoint knob [5] located under the cover (see "Dimensions").

The differential pressure switch is factory-calibrated in vertical position. Horizontal installation affects the switching point as follows:

- With cover facing upward: Switching point is 11 Pa higher than scale
- With cover facing downward: Switching point is 11 Pa lower than scale.

Disposal



The devices are considered electronics devices for disposal in term of European Directive 2012/19/EU and may not be disposed of as domestic waste.

- Dispose of the device via the channels provided for this purpose.
- Comply with all local and currently applicable laws and regulations.

Technical data

Electrical interface	Type of switch	Single-pole change-over, multi-layer contact	
	Contact rating	AC/DC 24 V, ≥ 0.01 A AC 250 V, max. 5 A res. max. 3 A ind., $\cos \varphi > 0.6$ (0.8 A starting current sixfold, $\cos \varphi > 0.6$)	
Warning	Voltage against earth	Max. AC 250 V	
	No internal fuse		
Functional data	External preliminary protection required in all cases		
	External supply line protection (EU)	Fuse slow max. 10 A or Circuit breaker max. 13 A Characteristic B, C, D according to EN 60898	
	Switching differential	Factory set	
	Reset	Automatic	
	Service life	>1 000 000 switching cycles	
	Measuring range	See "Type summary"	
	Max. unilateral overload		
		-30...75 °C	7500 Pa
		-30...85 °C	5000 Pa
		Permitted media	Air, non-corrosive gases
Degree of protection	Reproducibility for range		
		20...300 Pa	$<\pm 2.5$ Pa
		50...2000 Pa	$<\pm 5$ Pa
		1000...5000 Pa	$<\pm 15$ Pa
Materials	Protection class	III according to EN 60730-1	
	Protection degree of housing	IP54 according to EN 60529	
Mounting	Housing	Fiber-glass reinforced polycarbonate	
	Cover	Polycarbonate	
	Diaphragm	Silicone. low-swell rubber, emission-free	
	Mounting bracket	Sheet-steel (galvanized)	
	Duct adaptors	ABS	
Connections	Tubing	PVC, soft	
	Orientation	Any; See "Commissioning notes"	
Connections	Electrical connection	3 screw terminals	
	Cable entry	PG11 cable gland	
	Pressure connections	Male, dia. 6.2 mm	

Ambient conditions	Ambient temperature:	
	Operation	-30... +85 °C
	Storage	-40... +85 °C
Directives and Standards	Ambient humidity	<90 % r.h. (non-condensing)
	Product standard	EN 61326-x Electrical equipment involved in measurement, control, and laboratory use; EMV requirements; general requirements
	Electromagnetic compatibility (application)	For residential, commercial, and industrial environments.
	EU Conformity (CE)	CA1T1552xx ¹⁾
	EAC Conformity	Eurasia Conformity
	DVGW approval	to DIN 1854
	Combustion class	According to UL94
Combustion class	Pressure casing and housing	V-0
	Cover	HB
	Plastic tubing	V-2
	Duct adaptors	HB
Environmental compatibility	The product environmental declaration CA1E1552 ¹⁾ contains data on environmentally compatible product design and assessments (RoHS compliance, materials composition, packaging, environmental benefit, disposal).	
Weight	Weight (including packaging)	0.19 kg with mounting bracket

Connection terminals

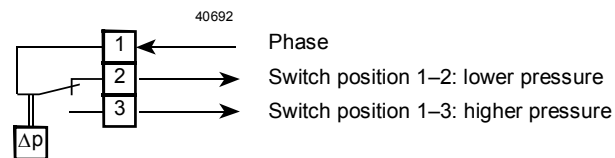

Dimensions

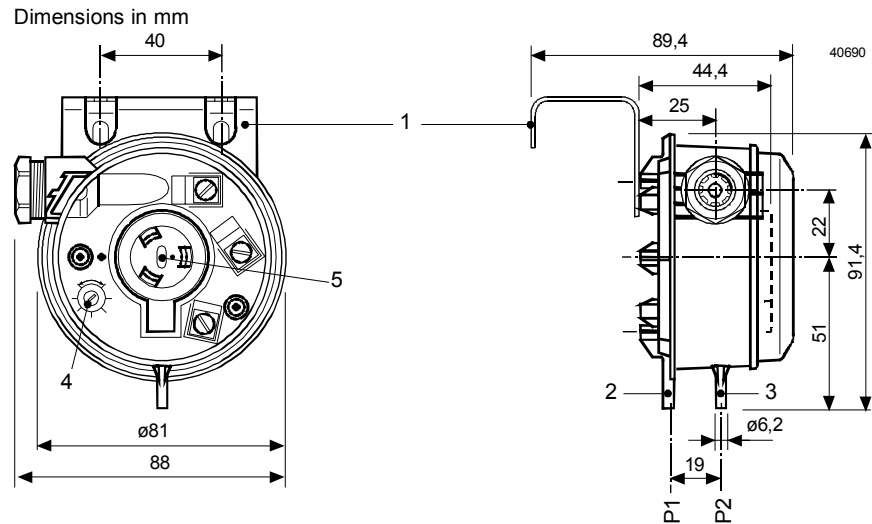

Key:

- 1 Mounting bracket
- 2 P1 connection, higher pressure
- 3 P2 connection, lower pressure
- 4 Pressure differential scale (factory-sealed with paint)
- 5 Setpoint knob

Duct adaptor

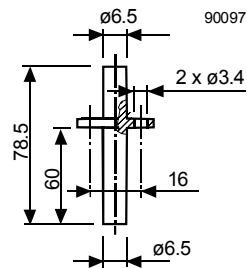

2 duct adaptors and 2 m tubing are supplied with the pressure switch.