

EasyflexTM

Single Arch Expansion Joints



- ⇒ Greater Movements.
- ⇒ Higher Pressure Ratings.
- ⇒ No gaskets required.
- ⇒ Absorbs & Isolates Vibrations/Noise/Shock.
- ⇒ Molded Design for better quality upto size 14" NB.
- ⇒ Reduces System Noise.
- ⇒ Absorbs Pipe Movement/Stress.
- ⇒ Compensates for Misalignment/Offset.
- ⇒ Available with tie rod assembly (Specially Recommended)
- ⇒ Size from 25mm NB to 1800mm NB.



Temperature Ratings

Standard (-) 10° to 70°C
 Special (-) 10° to 150°C

* Expansion Joints for special applications in different Polymers and Pressure ratings available as per customer specifications.

Movement Capability

Nominal Bore (mm)	Length (mm)	Axial Corp. (mm)	Axial Elongation (mm)	Transverse Deflection (mm)	Angular Movement		Torsional Movement Deg.
					Bore (mm)	Deg.	
20 - 25	125	12	6	12	25	14.5	3
					32 - 200	150	
250 - 500	200	19	10	12	75	10	3
					100	7.5	3
					125	6	3
					150	5	3
					200	5	3
					250 - 300	4	3
					350 - 400	2.5	2
					450 - 500	2	1
					550 - 600	2	1
					650 - 1000	2	1
1050 - 1800	300	25	12	12	500 - 600	2	1
					650 - 750	2	1
					850 - 1000	1.5	1
					1050 - 1800	1.5	1

*Standard PN10 and PN16 REJ design chart for sizes 25NB to 350NB available on next page

- ⇒ Due to policy of continual improvement, the specifications are subject to change without prior notice.
- ⇒ Measurements are subject to 5% tolerance.
- ⇒ To achieve good results do not over load fitting more than designed parameters as per drawing / catalogue.
- ⇒ Compliance - As per FSA Standards USA.

PN - 10

Nominal Size (I.D.)		Length Nominal f.f.	Flange Dia Nominal	Flange Thick	Expansion Joint Style	BS 10 Table D			ANSI 125/150# LBS			Operating Conditions	
INS.	MM	MM	MM	MM		Hole Dia	No. of Holes	B.C.D. (Approx)	Hole Dia	No. of Holes	B.C.D. (Approx)	Pressure Design	Test Pressure
						MM	NOS.	MM	MM	NOS.	MM		
1	25	150	114	14	EF 812	14	4	83	16	4	79	10 Bar	15 Bar
1.25	32	150	121	14	EF 812	14	4	87	16	4	89	10 Bar	15 Bar
1.5	40	150	126	14	EF 812	14	4	98	16	4	98	10 Bar	15 Bar
2	50	150	152	14	EF 812	18	4	114	19	4	121	10 Bar	15 Bar
2.5	65	150	178	14	EF 812	18	4	127	19	4	148	10 Bar	15 Bar
3	80	150	191	14	EF 812	18	4	146	19	4	152	10 Bar	15 Bar
4	100	150	229	14	EF 812	18	4	178	19	8	191	10 Bar	15 Bar
5	125	150	254	14	EF 812	18	8	210	22	8	216	10 Bar	15 Bar
6	150	150	279	14	EF 812	18	8	235	22	8	241	10 Bar	15 Bar
8	200	150	343	19	EF 812	18	8	292	22	8	298	10 Bar	15 Bar
10	250	200	406	19	EF 812	21	8	356	25.4	12	362	10 Bar	15 Bar
12	300	200	483	19	EF 812	21	12	406	25.4	12	432	10 Bar	15 Bar
14	350	200	533	22	EF 812	24	12	470	28.6	12	476	10 Bar	15 Bar

PN - 16

Nominal Size (I.D.)		Length Nominal f.f.	Flange Dia Nominal	Flange Thick	Expansion Joint Style	BS 10 Table E			ANSI 125/150# LBS			Operating Conditions	
INS.	MM	MM	MM	MM		Hole Dia	No. of Holes	B.C.D. (Approx)	Hole Dia	No. of Holes	B.C.D. (Approx)	Pressure Design	Test Pressure
						MM	NOS.	MM	MM	NOS.	MM		
1	25	150	114	14	EF 912	16	4	83	16	4	79	16 Bar	24 Bar
1.25	32	150	121	14	EF 912	16	4	87	16	4	89	16 Bar	24 Bar
1.5	40	150	126	14	EF 912	16	4	98	16	4	98	16 Bar	24 Bar
2	50	150	152	14	EF 912	19	4	114	19	4	121	16 Bar	24 Bar
2.5	65	150	178	14	EF 912	19	4	127	19	4	148	16 Bar	24 Bar
3	80	150	191	14	EF 912	19	4	146	19	4	152	16 Bar	24 Bar
4	100	150	229	14	EF 912	19	8	178	19	8	191	16 Bar	24 Bar
5	125	150	254	14	EF 912	19	8	210	22	8	216	16 Bar	24 Bar
6	150	150	279	14	EF 912	22	8	235	22	8	241	16 Bar	24 Bar
8	200	150	343	19	EF 912	22	8	292	22	8	298	16 Bar	24 Bar
10	250	200	406	19	EF 912	22	12	356	25.4	12	362	16 Bar	24 Bar
12	300	200	483	19	EF 912	25	12	406	25.4	12	432	16 Bar	24 Bar
14	350	200	533	22	EF 912	25	12	470	28.6	12	476	16 Bar	24 Bar

Standard Pressure Rating from 400 NB.

- 400 NB - 600 NB - 7.5 kg/sq cm²
- 650 NB - 1600 NB - 6 kg/sq cm²
- 1600 NB - 1800 NB - 4.5 kg/sq cm²

- ⇒ Higher Pressure Ratings and Movement Capabilities Available.
- ⇒ Expansion Joints are available in a variety of polymers for different applications duty conditions.
- ⇒ For Sizes above 1800 NB and also for Higher Pressure Rating Bellows can be designed as per customer requirement.
- ⇒ Vacuum - 26 inches of HG.
- ⇒ Please refer to our engineering department for special duty conditions/polymers.

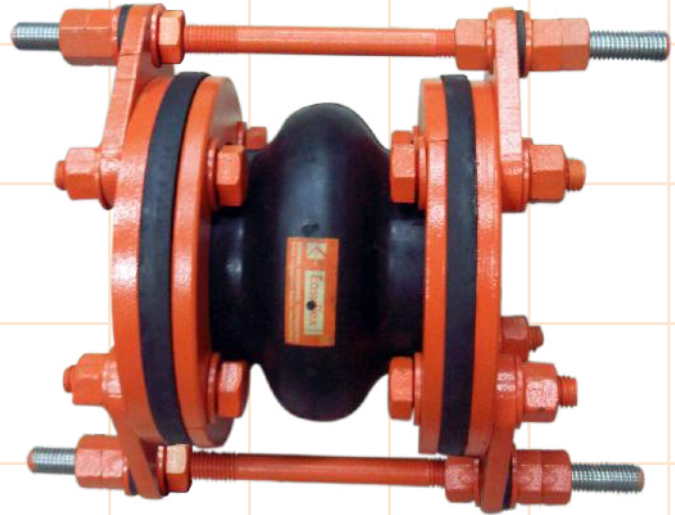
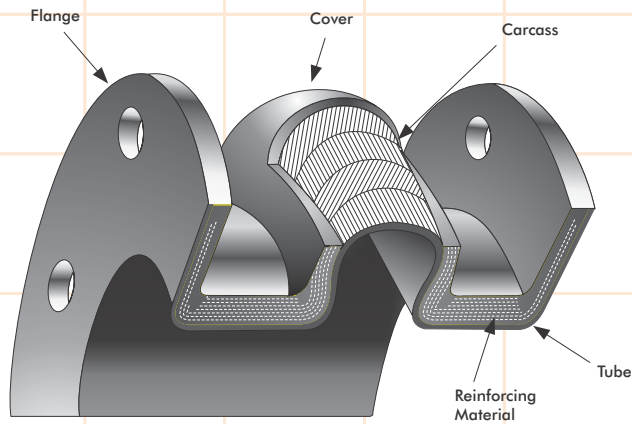

* Other Polymers available on request.

Arches - Can be filed if required, to avoid accumulation of sediment and to provide a smooth bore. However flexibility of joint is reduced by 50%

Cover - To protect body from atmospheric conditions or mechanical damages. NEOPRENE rubber is standard for weather, heat & oil resistance and long service life

Carcass - Consists layers of durable high tensile nylon/polyester cord for reinforcing the supporting member between tube and cover.

Flanges - Full faced integral with tube - are tough and non-compressible to reset flow under bolting pressure, having 'O' rings upto 12" nominal bore which should be fully flattened when installed in pipeline No Gaskets are required

Metal Retaining Rings (standard) - For distributing the bolting pressure around the flanges and to prevent the bolts from damaging the Rubber flanges when tightened.

Metal Reinforcements - Non-migrating metal rings are embedded in the body for extra strength, higher safety factor higher pressure and rigidity for vacuum service.

Steel rings are split, beveled and zinc electroplated. Galvanized rings also available.

Tube - Leakproof, Abrasion resistant Seamless lining of Rubber (synthetic or natural) is selected to ensure that joint will not be affected by passing medium (e.g., air, water, oil, gas, acid or chemicals)

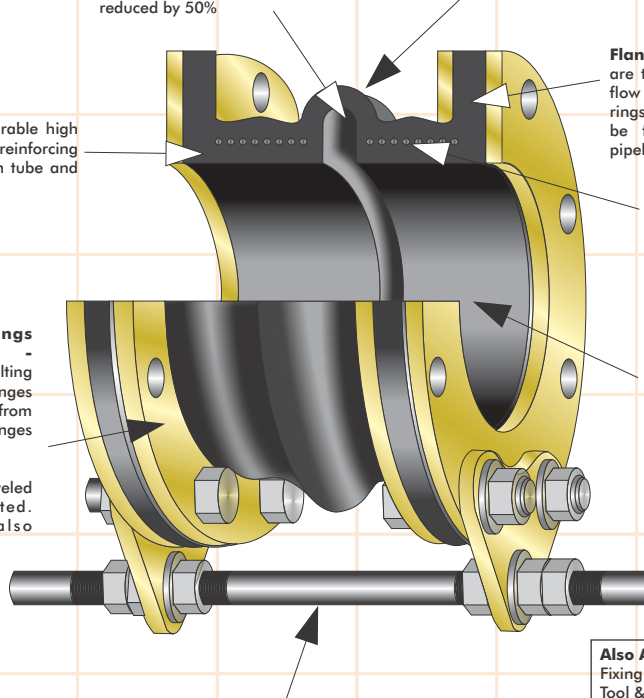

Control Rods (recommended) - To prevent damage to expansion joints by excessive elongation or compression of piping systems not anchored properly

Also Available - Companion Flanges, Fixing Bolts, Nuts and Washers, Fixing Tool & Tackles.

- ⇒ Due to policy of continual improvement, the specifications are subject to change without prior notice.
- ⇒ Measurements are subject to 5% tolerance.
- ⇒ To achieve good results do not over load fitting more than designed parameters as per drawing / catalogue.
- ⇒ Compliance - As per FSA Standards USA.

Why Control Units are Required :

- ⇒ Lack of Proper pipe anchors - Initial surge of pump at an elbow may cause hyper-extension.
- ⇒ Lack of proper pipe supports - Easyflex expansion joints and vibration dampeners are not designed to support the weight of the piping system.
- ⇒ Lack of proper alignment guides - Control rods will prevent lateral movement beyond design specifications.
- ⇒ Wide fluctuations of temperature - The changing from hot to cold media may cause excessive expansion or contraction even when the pipe is properly anchored.
- ⇒ Testing at elevated pressures - The use of anchors and/or control rods is required to offset the thrust.

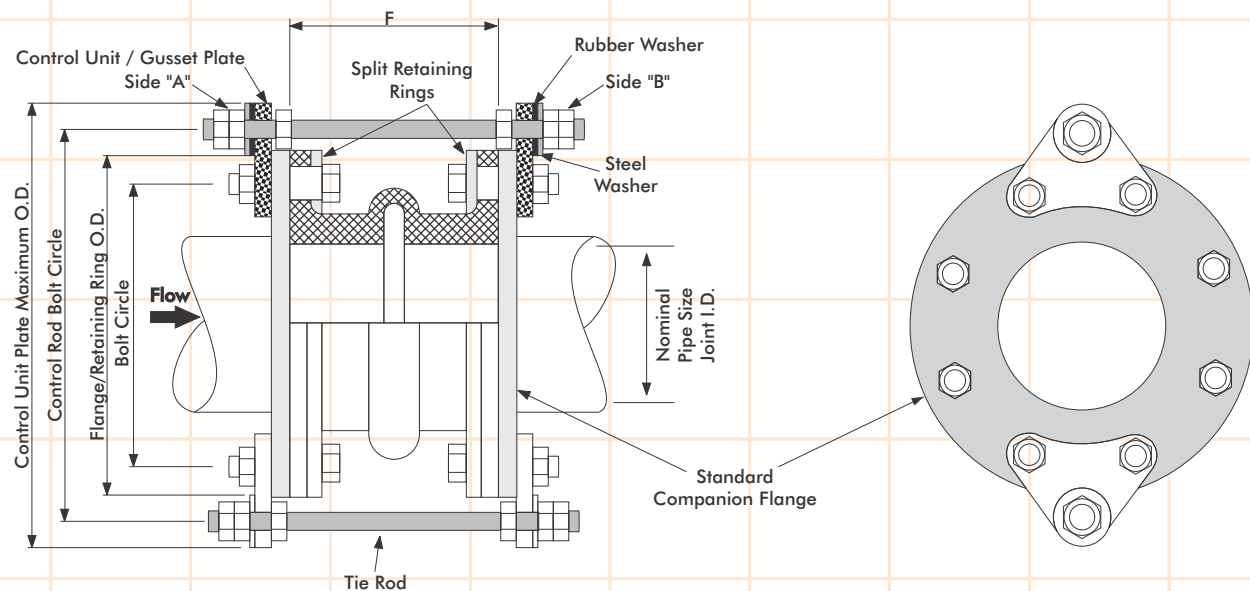

Pre-Installation Check List :

- ⇒ Compare the requirements of the system to ensure the proper number of control rods have been specified. (Minimum of two (2) required.)
- ⇒ Check Control Units to be sure all parts are included. The unit consists of minimum four (4) gusset plates, two (2) tie rods with six (6) nuts and six (6) metal / rubber washers. For bigger sizes and higher pressures the quantities might increase. Contact our Engg. Dept. or refer drawing.

Installation :

- ⇒ Bolt the control unit plates to the outer side of the Companion flanges at the same time while the bolt is being installed through the split retaining ring / rubber flange / companion flange and the control unit / gusset plates. They are to be equally spaced around the circumference of the flange.
- ⇒ Install the tie rod through the top hole in each gusset plate after placing rubber/metal washer on either side of the gusset plate. (See illustration above.)
- ⇒ Tighten the first two nuts ("A" location) in the direction of flow tightly. Check the recommended movement for the particular size from our catalogue and keep the second set of nuts ("B" location) loose accordingly. The second check nut should be tightened keeping space/gap for movement capability.

Note :

If excessive compression exists, optional compression sleeves should be specified. The compression sleeves will limit the compression to the maximum allowable movement.

- ⇒ Due to policy of continual improvement, the specifications are subject to change without prior notice.
- ⇒ Measurements are subject to 5% tolerance.
- ⇒ To achieve good results do not over load fitting more than designed parameters as per drawing / catalogue.
- ⇒ Compliance - As per FSA Standards USA.

Typical Piping Layout Utilizing Expansion Joint When Equipment and Piping are properly Anchored

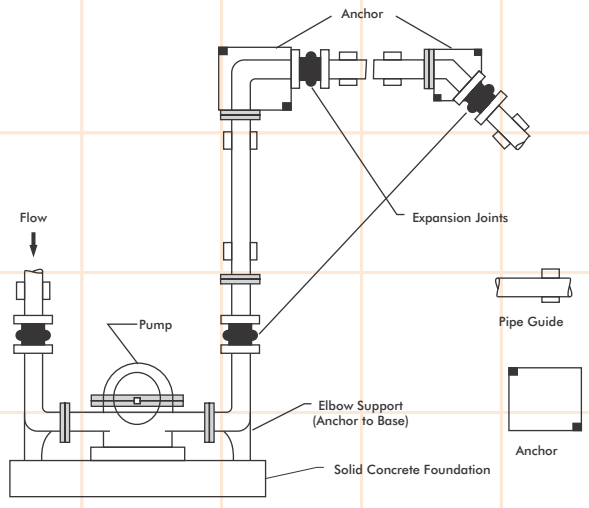

Typical Piping Layout showing the use of Control Units with the Expansion Joint when proper System Anchoring is Limited

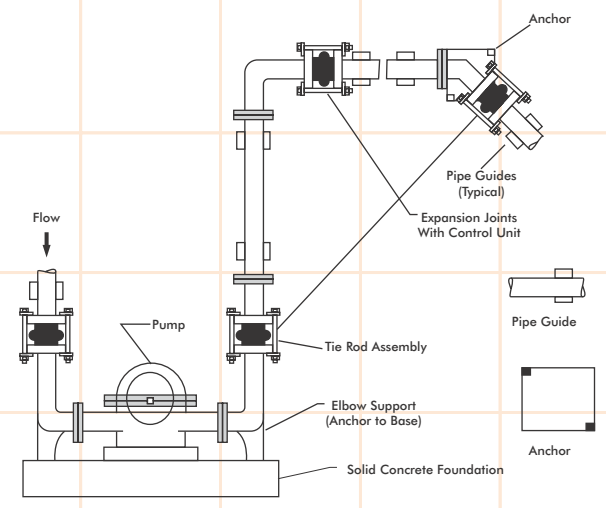

Use of an Inertia Base for Pump and Piping

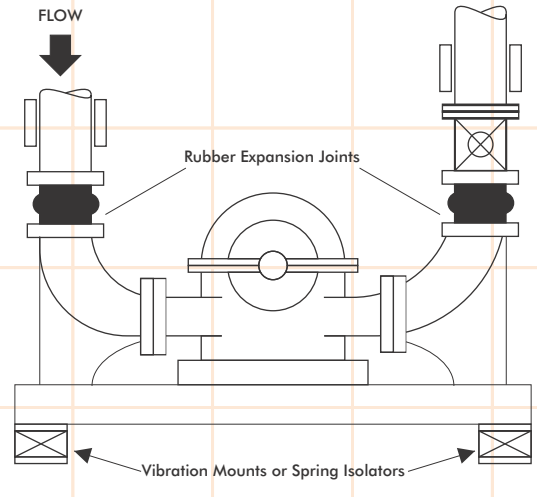

Superior Installation With Pump Base Independently Supported by Anchors

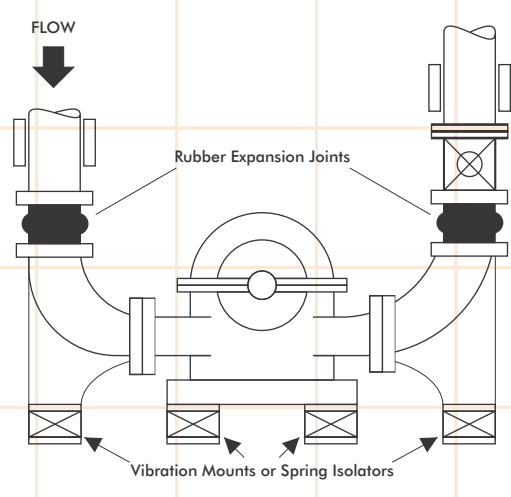

Typical Piping Layout Utilizing Expansion Joints and proper use of Anchors in Branch Locations

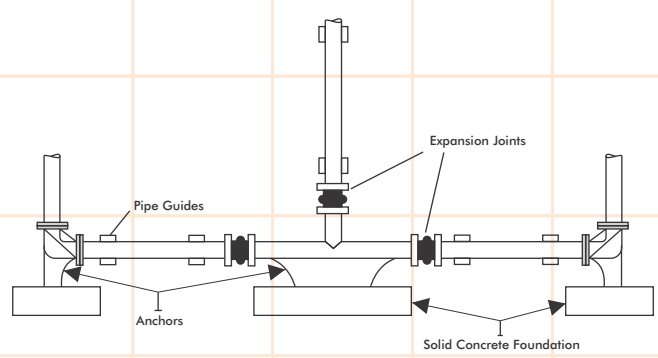

Typical Pump Installation With Expansion Joints Utilizing Vibration Mounts

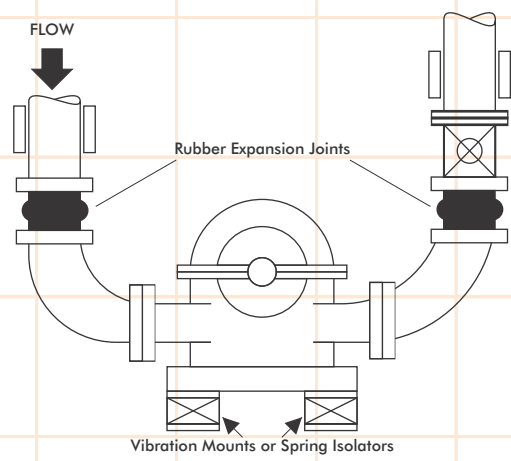

- ⇒ Due to policy of continual improvement, the specifications are subject to change without prior notice.
- ⇒ Measurements are subject to 5% tolerance.
- ⇒ To achieve good results do not over load fitting more than designed parameters as per drawing / catalogue.
- ⇒ Compliance - As per FSA Standards USA.

Site Pre Installation Check & Instructions :

- ⇒ Is type of Bellow/Joint correct for application.
- ⇒ Check maximum service temperature does not exceed maximum temperature specified in catalogue.
- ⇒ Are anchors suitable for the thrust generated.
- ⇒ Does pipework have adequate guiding and support.
- ⇒ Cold test pressure must not exceed 1.5 times the working pressure.
- ⇒ Area of movement of the joint must be free from obstruction.
- ⇒ Do not paint the rubber bellows/expansion joints (the outer cover is fully waterproof.)

Fitting Instructions :

The necessary steps for installing all expansion joints should be pre-planned. The installers should be made aware of these steps as well as the special instructions furnished with the expansion joint by the manufacturer, which will provide information necessary for proper handling and installation of expansion joints. The most critical phases of the expansion joint installation are as follows :

- ⇒ The installed length of the bellow in between the companion flanges should be equivalent to the over all length as per the Invoice.
- ⇒ No movement of the expansion joint (compression, extension, lateral offset, rotation) due to piping misalignment, for example, shall be imposed which has not been anticipated and designed into the movement capability of the expansion joint. Imposing such movements can result in systems malfunction or damage to the bellows or other components in the system. Specifically cycle life can be substantially reduced where forces imposed by attached equipment may exceed their designed limits, internal sleeve clearances may be adversely affected, and the pressure capacity and stability of the bellow may be reduced.
- ⇒ Anchors, guides, and pipe supports shall be installed in strict accordance with the piping systems drawings. Any field variances from planned installation may affect proper functioning of the expansion joint and must be brought to the attention of competent design authority for resolution.
- ⇒ Mating flanges must be smooth and must extend to the bore of the bellow/joint e.g. 100mm NB must be 100mm internal bore. There must be no grooves, protrusions or sharp edges applied to the rubber bellows/joint face.
- ⇒ Flange bolts should be located with their heads on the expansion joint side of the flange. If this location is not possible 10mm clearance must be made between the bolt and bellow/joint body.
- ⇒ Tighten bolts crosswise (not in rotation).
- ⇒ Protection for the body must be provided when welding in the vicinity of the rubber bellow/joint.

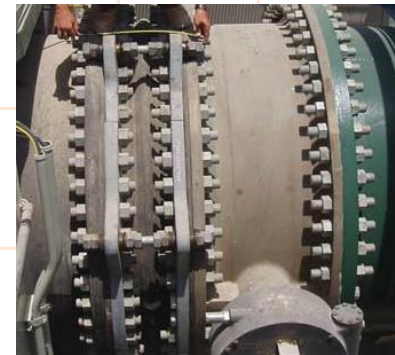

Post Installation inspection :

A careful inspection of the entire piping system shall be made with particular emphasis on the following:

- ⇒ Are anchors, guides and supports installed in accordance with the system drawings.
 - ⇒ Is the expansion joint in the proper location and is the installed length correct and have the control units been installed properly (Please refer to our catalogue).
 - ⇒ Are all guides, pipe supports and the expansion joints free to permit pipe movement.
 - ⇒ Are any expansion joints misaligned? Measuring the joint overall length and checking clearances at critical points on the expansion joint and at other points in the system can determine this.
- ⇒ Due to policy of continual improvement, the specifications are subject to change without prior notice.
 ⇒ Measurements are subject to 5% tolerance.
 ⇒ To achieve good results do not over load fitting more than designed parameters as per drawing / catalogue.
 ⇒ Compliance - As per FSA Standards USA.